



7/26/2006

"2005-06" Honda Foreman/Rubicon Winch Mount TRX500FM / TRX500TM / TRX500FE / TRX500FA

Part# 0506-HFORU

Kit Components:

Qty	Part Description
1.....	Winch Mount
2.....	1/4"- 20x1" x 1-1/2"U-Bolt (B1)
4.....	1/4"- Nylock Nuts (B3)
4.....	1/4"- Flat Washers (B2)
2.....	M8-1.25 x 25mm HH Bolt (B4)

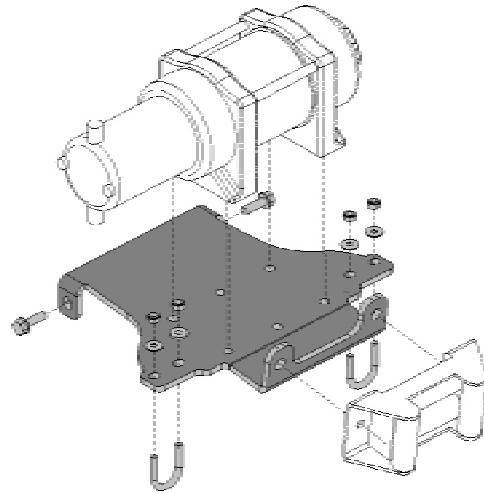

INSTALLATION INSTRUCTIONS:

NOTE: DISASSEMBLY OF THE FRONT OF YOUR ATV IS ONLY REQUIRED ON THE RUBICON TRX500FA MODEL. FOR ALL OTHER FOREMAN MODELS PLEASE START AT INSTRUCTION #6.

1. Begin by removing the front skid plate located on the front of your ATV. Remove the (4) side 8mm bolts and the (4) 6mm bolts securing the front skid plate.
2. Remove the (4) plastic rivets on each side of the front plastic fascia. Use a large screwdriver to carefully remove the center rivet. After removing the center rivet, remove the rivet housing.
3. Remove the (2) 6mm bolts that attach the front bumper to the plastic headlight assembly.
4. Remove the (2) top 8mm bumper bolts that attach the front bumper to the front rack..
5. Remove the (2) bottom bumper bolts that attach the bumper to the bottom of the ATV Frame.
6. Remove the (2) middle bumper bolts that attach the bumper to the middle of the ATV frame. These two bolts will be replaced with the (2) supplied M8 bolts.
7. Place the mounting plate into position on the front bumper. Install (2) U-bolts (B1). (4) washers (B2), and (4) lock nuts (B3) that are supplied with this kit. *Do not lighten U-bolts at this time.*
8. Attach fairlead to the fairlead mounting location using hardware supplied with your winch or fairlead. (*not included with this kit*) Torque fairlead bolts to approx. 25 ft-lb.



9. Mount your winch to the mounting bracket using the supplied hardware with your winch. (*not included with this kit*)

10. If your ATV is a Rubicon you can now place the front bumper with attached winch assembly back onto the ATV frame. Reinstall the (4) bolts that were removed in steps 4 & 5. Do not tighten at this time.

11. Install the supplied 8mm bolts, into the middle bumper mounting location. Step 6. Do not tighten at this time

12.If your ATV is a Rubicon you can now reinstall the (2) 6mm bolts that were removed in step 3, the (4) rivet fasteners that were removed in step 2, the front plastic skid plate that was removed in step 1, and the (4) side 8mm bolts and (4) bottom 6mm bolts. Do not tighten at this time.

13.Now you can tighten all nuts and bolts to the recommended torque of:

- 6mm bolts-12 N-m (9 ft-lb)
- 8mm bolts -37 N-m (27 ft-lb)
- 1/4" U-bolts-10 N-m (7 ft-lb)

14.Using the instructions provided with your Winch, wire accordingly.

RECOMMENDED CONTACTOR LOCATION

1. Contactor Location

- a. The contactor location is located in the right rear inner fender, on the right side of the rear tool box,
- b. Remove the wire harness, from the bracket that holds the wire harness in position.
- c. Using a drill and a 1/4" drill bit, remove the top of the rivet head to remove the wire harness bracket.
- d. Relocate the wire harness that was removed along the rear rack tube. Use a zip-tie to secure the wire harness.
- e. Position the contactor with the posts for the positive battery cable in the lower left corner. Mark and drill 1/4" holes for the contactor. Secure the contactor with hardware supplied with your winch. Tighten the nuts to a recommended torque of 5 ft-lb.